

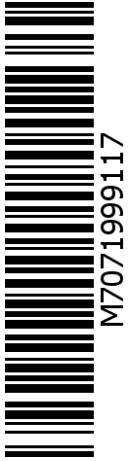

System 7071999117**Advantage over original system****System Generator/ignition for Aermacchi Sprint and Aermacchi 250N/SST/SX**

- nicht für E-Start
- Replaces stock alternator and complete ignition system. Updates your system to solid state ignition and 12V/150W output. There is no need for changes on engine casing. The system is technically capable to run without battery.
- Can not be used on engines with electric start models.

- all parts are new
- more light output
- very stable ignition with solid spark
- better starting, better fuel burning
- no wear any more on points
- no worry any more over centrifugal governor



Assembly instructions for system 7071999117 and 7071999120	11.7.2022
<p>- If you can install and time a stock ignition and possess basic mechanical skills, you can install a VAPE! If you never have worked on your ignition, better have it done by someone who knows.</p>	
<p>- VAPE can not monitor the compliance to those instructions, nor the conditions and methods of installation, operation, usage and maintenance of the system. Improper installation may result in damage to property and possibly even bodily injury. Therefore we assume no responsibility for loss, damage or cost which result from, or are in any way related to, incorrect installation, improper operation, or incorrect use and maintenance. We reserve the right to make changes to the product, technical data or assembly and operating instructions without prior notice</p>	
<p><u>IMPORTANT</u></p>	
<p>- Please read these instructions fully and carefully before starting work on your motorcycle Please bear in mind that any modification of the material as well as own repair attempts which have not been agreed with VAPE may result in a loss of warranty. Do not cut off wires. This leads to a loss of reverse polarity protection and often results in damage to electronics. Also, please take note of the information provided on the information page for this system. Check that what you have bought really corresponds to the motorcycle you have. Wrong ignition settings may damage your engine and even hurt you during kickstart (violent kickbacks). Be careful during the first test runs. If needed change settings to safer values (less advance). During assembly check carefully that the rotor (flywheel) does not touch the stator coils or anything else, which may happen due to various circumstances and lead to severe damage.</p>	
<p>Designated use - This system is designated to replace stock dynamo/alternator & ignition systems in vintage and classic motorcycles whose engine characteristics have not been modified aftermarket. This system is not a tuning system and it will not bring significant increases in engine output. It does however significantly enhance roadworthiness and comfort by offering better lighting, better function of side indicators and horn and, compared with the aging stock systems, increased reliability. As our system does not tamper with engine characteristics it does not increase emission of gaseous pollutants and noise. In most cases emission of pollutants should even be reduced due to better combustion. If used as designated the system therefore will not normally infringe the existing legal status of the motorcycle. (Please check your local legal regulations!) This system is not suitable for use in competition events. If used other than the designated way, your warranty will be voided and it might well be that you do not obtain the desired results or, worst you loose legal roadworthiness.</p>	
<p> - VAPE guarantees homologated products marked with the "E" mark in the ring (E8 specifically for the Czech Republic), thereby ensuring a consistent conformity of the product properties with the relevant ECE homologation regulations (especially ECE R10.05). Inspection is regularly carried out by the competent authority.</p>	
<p>- The charging system is only suitable for use with rechargeable 12V (6V systems 6V) lead-acid batteries with liquide electrolyte or sealed lead-acid batteries, AGM, Gel. It is not suitable for use with nickel-cadmium, nickel-metal-hydride, lithium-ion or any other types of rechargeable or non rechargeable batteries.</p>	
<p>- This is a replacement system and not a copy of the stock material. The parts in this system therefore look different and might fit differently (notably ignition coil and regulator) requiring some adaptation by you.</p>	
<p>- During assembly imperatively start with assy of engine based parts to see that those really fit before you start fitting the external parts. In many cases customers assemble those first and thereby often modify them in breach of warranty which renders them unfit for renewed sale. Replacing old ignition systems is not a matter of taking something from a supermarket shelf as there have been very many types, versions and possibly unknown aftermarket modifications which harbour plenty of room for error.</p>	
<p>- Our systems are NOT tested for use with third party electronic devices (such as GPS, mobile phones, LED lighting etc) and may cause damage to such parts. Possibly existing electronic tachometers will not work with the new system. Possibly existing safety switches and electronic valve controls are not supported. It might be that your motorcycle was originally equipped with an ignition that did limit top speed for legal reasons. The new system does not have such a facility, so check your legal situation beforehand.</p>	

- If you have no expertise for the installation have it done by an expert or at a specialist's workshop. Improper installation may damage the new system and your motorcycle, possibly even lead to bodily harm.

- Before you order a system, please check whether a puller tool for the new rotor is included in the kit. If not, better order it at the same time. Never use anything other than the recommended puller tool to pull the new rotor again. Damage to the rotor as a result of use of other tools or methods is not covered by your warranty.

- The rotor is sensible to blows (including during transport). Before assembly, please always check for damage (on rotor without magnet plastification try to push the magnets aside with your fingers). After impact the glued in magnets might have broken loose, sticking to the rotor solely by magnetic force, so that one does not notice right away. During engine run the damage would be considerable. Before placing the rotor onto the engine, please make sure that its magnets have not collected any metal objects such as small screws, nuts and washers. That equally would lead to severe damage.

- **If you have access to the Internet, best view those instructions online.** You get larger and better pictures by clicking onto them and possibly updated information. System list at <http://www.powerdynamo.biz>



- To disengage your new rotor again, you will need a puller M27x1,25 (part 99 99 799 00 -Not provided!-).

- Note: Never use a claw puller, a hammer or any other device, that will shake the magnets off.



- **You should have received those parts:**

- Please observe that the sensor (pickup) is only loosely mounted by us, as you have to set its gap. Tighten the screws carefully after setting.

- Depending on choice of system you will either find an ignition coil with only one exit or a double coil with 2 exits.



- Make sure your motorcycle rests securely, preferably on an elevated work bench and that you have good access to the generator side of the engine.

- Disconnect your battery and take it out of the motorcycle. Note, that you will install a 12 volts system, so you will either need a 12 volt battery or you use the option of driving without. You will still have to replace all lightbulbs to 12 volt ones. The horn may stay at 6 volts.

In a first step, old parts will be taken off the bike



- Unscrew the generator cover and take it off. Disconnect the wires from the old dynamo. Pull all wires out of the engine housing, but do not cut any wires yet.
- Unscrew the old stator (2 screws) and take it off the engine. Pull the rotor off, you will need a puller screw for this.
- Disconnect the wires from your old ignition coil and remove the coil.
- The ignition parts at the right side of your engine (points and governor) will not be used any more. You may leave them there or remove them.

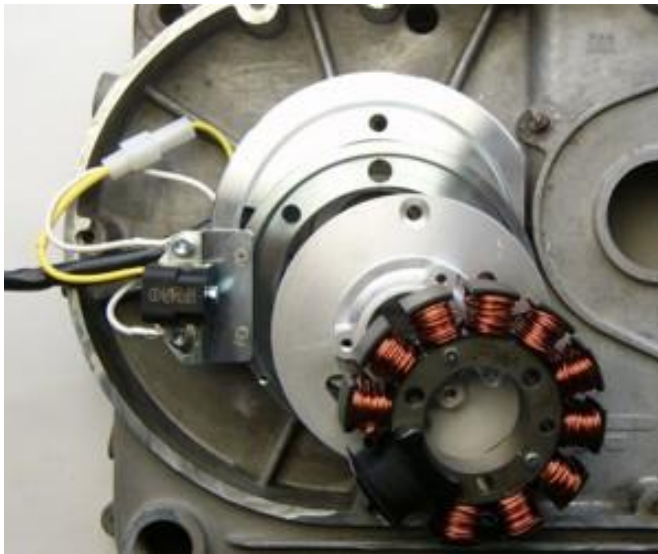

- The new stator unit has of 3 plates.
 - a thicker aluminium base (adapter)
 - a steel ring with holder plate for pickup
 - the holder plate for the actual coil
- Take the 3 pre-assembled screws M4 off and pull the stator a little away from the base (to get access to the screws).



- Place the bottom adapter onto the engine, flat side to sprocket, wire opening to front.
- Place the steel ring and the stator base into it. The pick up will show into the direction of about 10 o'clock.
- Screw all 3 plates down with the 2 supplied countersunk screws M5x30.



- Put the stator coil back onto the plate, take care not to damage the wires.

- Make sure that the inner opening of the stator unit slots evenly over the elevated fixing rim of the base plate - otherwise the coil will sit lopsided and will touch the rotor, damaging it. Screw the coil down with the 3 screws M4x30 and tighten.

- Lead the wire out of the wire exit of the engine. Depending on diameter there you might have to enlarge the hole a little. Put a rubber grommet for protection.



- On the motorcycle, the whole assembly will look something like this.

Timing is done with crankshaft in TDC position (no matter which cycle)



- Have a look at the new rotor. You will find on the circumference some long protrusion and a lasered on line which goes right up to the top where it is marked with a "0R".

- The elevated sign is there to trigger ignition. However it does not do so when this elevation reaches the sensor, but after it has gone past it as the system needs to calculate the advance based on engine speed (the time the protrusion needs for one passage used as reference).

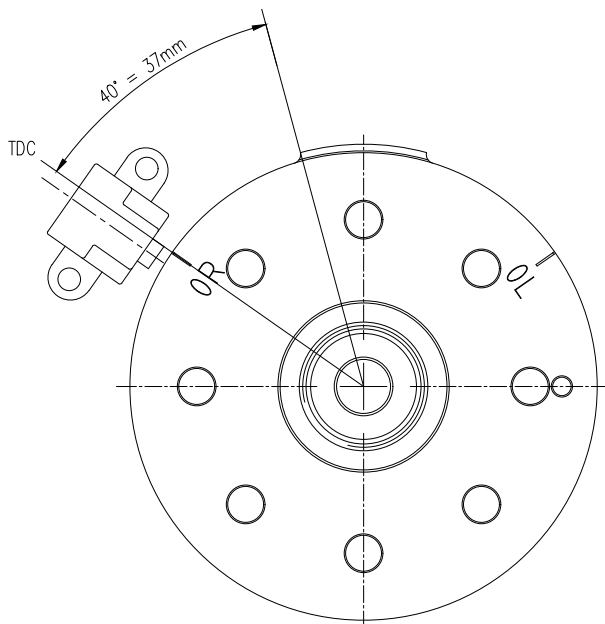

- Then place the rotor back onto the shaft in such a way, that the 0R-marking line aligns with the rh edge of the sensor pin as shown in the sketch here.

- Now fasten the rotor with the supplied screw (and washer). Make sure not to change the crank's position during this.



- Should you have a rotor that does not yet have the 0R-line than you can place this marking easily by yourself as follows:

- Cut some strip of paper with **37mm** length, place this on the left side of the trigger sign and mark its end on the circumference with some marker pen. You then have the needed marking.

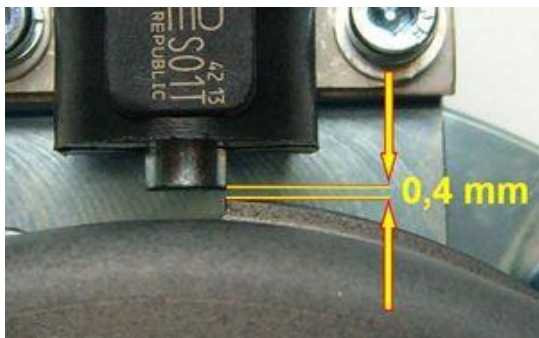

- Put the rotor on but do not tighten it yet. Then turn the rotor slowly by hand and check clearance between the sensor and one of the rotor noses. This has to be ca. 0.4-0.5mm.

- You may adjust the gap by loosening the 2 holder screws of the sensor and shifting it a little.

- Do not forget to tighten the 2 holder screws of the sensor carefully. If loose, the sensor will get into contact with the rotor and will be destroyed.



- It might well be that after some test runs you may wish to modify timing a little. After all, there are more than one type of Aermacchi and out setting is a standard fail safe one.

You change timing by:

- screwing the puller into the rotor, popping it from the crank
- and (without changing the position of the crank) resetting the rotor at the wanted angle.
- Setting it more into a clockwise position will initiate earlier timing.
- shifting it anticlockwise will make it later.

- Now, the new ignition coil, the advance unit and the new regulator/rectifier have to find a place on the motorcycle. The regulator is well dimensioned and does not need to put it into direct airflow. Here in pictures a few propositions of where to fix the parts.

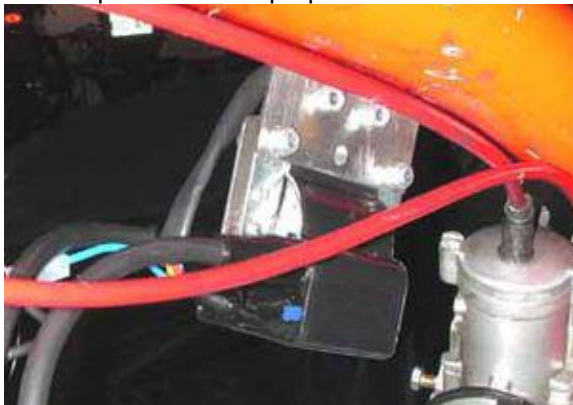

- Before installing the advance unit, have a look at the small switches at the advance unit. They activate different characteristics. There are 4 switches activating different advance curves.



- Best most suitable curve for Aermacchi is activated with switches 1,2,3 to OFF and 4 to ON (opposite off) This retards 9° at start and advances to 34° from 3000 revs/min onwards.

	<p>- with this setting the engine starts at 2° and advances till 38°</p>
	<p>- Set switches to the positions indicated here: It gives a retard at 5° at start up till tickover and than advances to 40° at 3,500 revs.</p>

Connect the parts as shown in wiring diagram 91xk12!

- To facilitate wire exit through the often small openings in the engine casing, the plastic plug of the generator's wiring that leads to the ignition coil have not been put onto the wire terminal. You should place the plug there only once all has been properly installed on the engine side.



- Look for the advance unit with its female plug and the three wires (red, yellow and white).
- Put the provided 4-position plug housing onto this plug and insert the three wires (red, yellow and white) from the generator. Make sure that the terminals engage securely in the housing and that you connect:
 - red to red
 - yellow to yellow
 - white to white

- Should you need (or want) to get the terminals out of the plug housing again, enter a paper clip from front next to the terminals and push the little barb aside. Than pull the wire out.

The second plug at the advance (a male plug) will be connected to the plug at the ignition coil. This two plugs can only be connected in one position. Note the changing colours:

- red to red
- white of the advance unit to brown of the ignition coil
- blue/white of the advance unit to yellow of the ignition coil

Important! Never run the high tension cable(s) and the cable(s) of the advance unit closely in parallel (say in one shielding). This will trigger back coupling that disturbs ignition and might even damage the advance unit.

Connecting VAPE alternator to lighting circuit (via regulator):



- The 2 black wires running from the stator coil carry the voltage for lights, horn, flashers etc. They have nothing to do with ignition.
- This voltage (something between 10 and 50 volts AC) has however to be stabilized (regulated) and for most uses rectified into direct current (DC) as it primarily is alternating current (AC).

- For this we offer 2 different regulators:

Attention: Any confusion between plus and minus (with the DC versions) leads to immediate destruction of the regulator. This will not constitute a warranty case as it is negligence! One can recognize a burnt regulator mostly by its sharp smell.

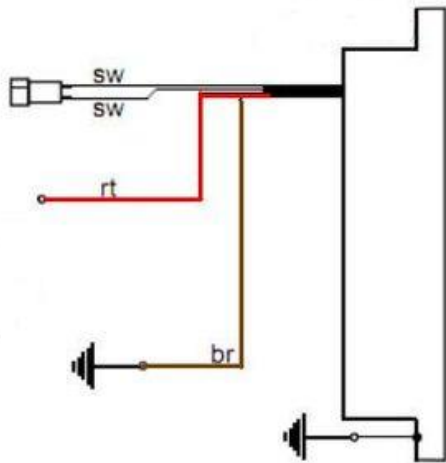
Regulator with DC regulator with built in smooting condenser (73 00 799 50):

- the 2 black (sw) wires are the AC input from the alternator (as it is AC it does not matter which black to which black)
- the red (rt) wire is the 12V DC output plus
- the brown (br) wire is ground, internally connected to housing

- Remains the blue (sometimes blue/white) wire at the ignition coil. This is the kill (cut-out) wire.

- Connected to ground - it will stop ignition!

- This type of wiring is used in motorcycles which originally already had magneto ignition and therefore switched off by shortcircuiting against ground.

- Those vehicles have by design a main lock (or some kill switch) that connects a pin to ground when in OFF position (German bikes: pin 2). The blue/(white) wire of the ignition coil will be connected here. In that way the cut-out works like previously.

- Screw the high tension (ignition) cable ...

- Please do not use any spark amplifying cables, such as "Nology supercables" or "hot wire". This will disturb the system and possibly damage it.

... into the ignition coil and pull over the rubber seal before mounting the coil (it will be easier).

- Please do use the cable arriving with the pack and not any old cable.

- You will be doing yourself a favour to treat your bike to new spark plugs and spark plug caps (preferably some between 0-2kOhm). Plenty of problems are to be traced back to "apparently good" (even completely "brand-new") sparks plugs, terminals and cables.

Do not use spark plugs with an intern suppression resistor. NGK (e.g.) offered such spark plugs coded with an "R" (for resistor).

- Finally - and before installing the battery and before the first attempt to kickstart - please re-check carefully all connections and fitments with the wiring diagram. Do check battery and light bulbs for correct voltage (12V).

Should something not work, please consult our trouble-shooting guide on our homepage. As a first step disconnect the blue wire from the coil and re-test.

- **IMPORTANT:** During crank shaft repair the dynamo shaft is often machined and gets shorter. The result is a rotor sitting lower, possibly touching now with its rivets the stator coil. The result is a destroyed stator and ignition failure.

Important safety and operating information

- Safety first! Please observe the general health and safety regulations motor vehicle repair (MVR) as well as the safety information and obligations indicated by the manufacturer of your motorcycle. The timing marks on the material are for general guidance only during first installation. Please check after assembly by suitable means (stroboscope) that settings are correct to prevent damage to the engine or possibly even your health. You alone are responsible for the installation and the correctness of settings.

- Ignition systems generate high tension! With our material right up to 40,000 Volts! This may, if handled carelessly, not only be painful, but outrightly dangerous. Please do keep a safe distance to the electrode of your spark plug and open high tension cables. Should you need to test spark firing, hold the spark plug socket securely with some well insulating material and push it firmly to solid ground of the engine block. Never pull sparkplug caps when engine is running. Wash your vehicle only with engine at standstill and ignition off.

- You should have received the HT Cable with the fixed rubber cap (*which does not contain a resistor*) as a part of the kit, you should have to use a spark plug with an inbuilt resistor (*or replace the cap with the one containing a resistor*) to comply with your local laws (*Electromagnetic compatibility requirements*).

- Do not use a spark plug cap(s) containing a resistor **WITH** a spark plug(s) containing a resistor at the same time. It would cause problems, especially difficult engine starting. The total resistance of cap and spark plug combined should not exceed 5kOhm.

- Remember that candle plugs age, increasing resistance. If an engine only starts when it is cold, it is very likely that a defective spark plug connector or faulty spark plug is the cause. Do not use so-called ignition-reinforcing cables (e.g. Nology).

- After installation, please check tightness of all screws, even those preinstalled. If parts get loose during run, there will be inevitably damage to the material. We pre-assemble screws only loosely.

- Give the newly installed system a chance to work, before you start to check and test values, or what is worse apply changes to it.

Our parts have been checked before delivery to you. You will not be able to check much anyway. **At any rate do refrain from measuring the electronic components (such as ignition coil, regulator and advance unit). You risk severe damage to the inner electronics there. You will not get any tangible results from the operation anyway.** Bear in mind that also your carburetor, your spark plugs and spark plug sockets (even if completely new) might be the reason for malfunction. The general experience with our systems is that the carburetor will have to be re-adjusted to lower settings. Should the system not start after assembly, first disconnect the blue (or blue/white) cut-off wire directly at the ignition coil (or in some cases advance unit) to eliminate any malfunction in the cut-off circuitry. Check ground connections carefully, make sure there is a good electrical connection between frame and engine block. In case of troubles, please consult our Knowledge Base first before you send off the material to us for checking.

- The spark of classic, points based ignition systems has with about 10,000 Volts comparatively little energy and looks therefore yellow and fat (which however makes it highly visible). The spark from our system is a high energy spark with up to 40,000 Volts and therefore is needle thin focused in form, and blue in colour, which makes it not so visible. Furthermore you get spark only at kick-start operated speeds and not by pushing the kick-lever down slowly with your hand (as you might get with battery based ignitions).

- Systems using a twin outlet ignition coils have a few peculiarities. Please observe that during tests on one side, the other has either to be connected to an fitted spark plug or securely earthed/grounded. Otherwise there will be no spark on either side. Also with such open exits long and dangerous sparks may fly all over the coil.

- Never do electric arc welding on the bike without completely disconnecting all parts containing semiconductors (ignition coil, regulator, advance) stator and rotor need not be taken off. The same is true for soldering. Before touching electronics disconnect the soldering iron from mains! Never use copper putty on spark plugs.

- Electronics are very sensitive to wrong polarity. After work on the system, do check correct polarity of the battery and the regulator. Wrong polarity creates short circuits and will destroy the

regulator, the ignition coil and the advance unit. As a rule, wiring will always be colour to colour. Instances, where colour jumps between wires are expressly mentioned in our instructions.

- When you handle the new rotor, take care not to damage its magnets. Refrain from direct blows to the circumference of the rotor. **When transporting never put the rotor over the stator.** Observe our information relative to transport of the material.

- Do not use spark plug sockets with a resistance of more than 5kOhm. Better use 1 or 2kOhm ones. Bear in mind that spark plug sockets do age and thereby increase their internal resistance. Should an engine start up only when cold, a defective spark plug socket and/or spark plug is very probably the cause. In case of problems check high tension cables too. Never use carbon fibre HT-cables, never use so called "hot wires" which promise to increase spark.

- It is a good idea to cover the rotor in a thin layer of oil to reduce the risk of corrosion.

- Never use a claw puller or a hammer to disengage the rotor. Its magnets might become loose in the event. We offer a special puller for disengaging the new rotor again (see assembly instruction)!

- Should the motorcycle not be in use for some longer period, please disconnect the battery (so existing) to prevent current bleeding through the diodes of the regulator. Though, even a disconnected battery will empty itself after a while.

- Please do observe these remarks, but at the same time, don't be afraid of the installation process. Remember, that before you, thousands of other customers have successfully installed the system.

Enjoy driving your bike with its new electric heart!

