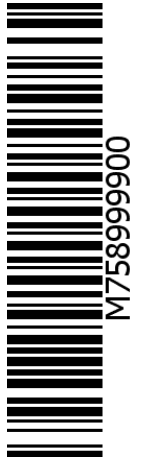

System 758999900**Alternator/electronic ignition system for Motobecane C/D/U 45-A/B/S**

- Magneto lighting system with integrated, speed-dependent, fully electronic ignition. Lighting output 12V/100W DC. Contactless electronic ignition with its own power supply within the system. Replaces the old alternator, breaker and ignition coil. No modifications to your engine casing are required. Technically speaking, the system is capable of operating without a battery.

**Advantages over the old system:**

- all parts are new
- significantly brighter light
- very stable ignition with high-energy sparks
- better starting and improved combustion
- no more wear on the breaker

Installation instructions for System 758999900	28 April 2026
<p>- If you are able to fit and adjust the original ignition system and have general mechanical skills, you can also fit a VAPE system. If you have never dealt with this before, it is best to have the system fitted by someone who is familiar with it.</p>	
<p>- VAPE is unable to monitor compliance with these instructions, or the conditions and methods relating to the installation, operation, use and maintenance of this system. Incorrect installation may result in damage to property or even personal injury. We accept no responsibility or liability for any loss, damage or costs arising from, or in any way connected with, faulty installation, improper operation, or incorrect use and maintenance. We reserve the right to make changes to the product, technical specifications or installation and operating instructions without prior notice.</p>	
<p><u>IMPORTANT</u></p>	
<p><u>Please make sure you read the entire manual carefully before you begin installation</u> Please bear in mind that unauthorised modifications, including attempts at repair, to the components may result in the loss of warranty rights. This also applies to cutting cables, which very often leads to the loss of reverse-polarity-protected connectors and, consequently, to short circuits or reverse polarity that can damage the components. Please note the instructions on the system information page. Ensure that the system configuration shown actually meets the requirements of your engine. Incorrect ignition settings, for example, can certainly damage the engine and/or cause injury when starting (kickback from the kickstarter). Particular caution is required during the first start-up after installation. If you notice any malfunction, check and adjust the ignition timing! During installation, check very carefully that the rotor is not rubbing against the stator coil or anywhere else, as this can occur for various reasons and lead to serious damage.</p>	
<p><u>Intended use</u> - This is a replacement system and not a copy of the original equipment. The components of the system therefore look different from the original parts, and in particular the ignition coil and regulator may have different mounting points, requiring you to make adjustments. This system is intended exclusively for replacing original lighting/ignition systems in classic and modern classic motorcycles whose engine characteristics have not been subsequently altered by design modifications. It is not a tuning system; it does not alter the original engine characteristics and does not result in significantly higher engine power. However, it does improve the roadworthiness and safety of the vehicle through better lighting, clearer indicators, a consistently loud horn and, compared to the ageing original systems, greater overall reliability. As our systems do not cause any significant change to the engine characteristics, exhaust and noise emissions are not adversely affected. In most cases, exhaust emissions are likely to improve, as combustion becomes more complete.</p>	
	<p>- VAPE guarantees type-approved products marked with the letter 'E' (specifically 'E8' for the Czech Republic), thereby ensuring that the product specifications consistently comply with the relevant ECE type-approval regulations (in particular ECE R10.05). Inspections are carried out regularly by the competent authority</p>
<p>- The charging system is strictly intended for use only with rechargeable 12V (6V systems 6V) lead-acid batteries with liquid electrolyte or sealed lead-acid batteries, AGM, and gel. It is not suitable for use with nickel-cadmium, nickel-metal hydride, lithium-ion or other types of rechargeable or non-rechargeable batteries.</p>	
<p>- The system is not suitable for use at sporting events. If the system is used for purposes other than those for which it is intended, the warranty will lapse. Furthermore, the system may not perform as you require, and we will be unable to assist you via our support service as we will not be aware of the situation. In the worst-case scenario, improper use may even result in the withdrawal of the operating licence.</p>	

- **When fitting the parts, you must start by fitting the engine-side components** (adapter, stator, rotor) to check that they actually fit before fitting the parts that are to be mounted outside the engine. Unfortunately, it is often the case that people start by fitting the regulator, ignition coil and, where applicable, the control unit, and these parts are very often modified (incorrectly!) in the process, which makes it impossible for us to resell them later. Unfortunately, replacing the lighting and ignition systems on older motorcycles is not like picking something off the shelf in a supermarket; given the wide variety of models and the possible changes to the components since they were first produced many years ago, it is always a complex matter that can, regrettably, also involve errors.

- Our systems have **NOT been tested for use with other electronic components (such as third-party ignition systems, sat-navs, mobile phones, LED lights, etc.)** and may cause damage to such components under certain circumstances. Any existing rev counters are not supported by the system. However, we do offer a rev counter solution. Similarly, any circuit breakers or ignition-controlled exhaust systems are not supported. It may also be the case that your original ignition system had a speed-limiting device fitted for legal reasons. The new system does not have such a device. You should therefore check the legal situation beforehand.

- If you do not have the necessary expertise to carry out the installation, please have it done by a qualified professional or a specialist workshop. Incorrect installation may damage both the new system and the motorcycle, or even result in injury to the rider.

- Before ordering a system, please check whether the **rotor puller** we recommend is included in the scope of delivery. If not, it is best to order it at the same time! If the rotor is damaged by the use of other tools or aids, the warranty claim will be void!

- The rotor is extremely sensitive to impact (e.g. including during transport). You must always check the rotor for any damage before installation. If the rotor has magnets that are not encapsulated, check that the magnets are securely in place by trying to push them sideways with your fingers. Following an impact, some of the glued-in magnets may have become loose and are now held in place solely by their magnetic force. This would cause serious damage to the system during operation. At the same time, please check the rotor's magnets for foreign objects (e.g. screws or other metallic items).

- **If you have internet access, it is best to view this documentation online.** You can enlarge most of the images by clicking on them, and you will find more detailed and possibly more up-to-date information. System list available at: <http://www.powerdynamo.biz>



You should have received the following parts:

- Pre-assembled stator plate
- rotor
- Ignition coil
- Control unit
- Regulator/rectifier with smoothing capacitor
- Ignition cable
- Small parts



- To remove the new rotor again, you will need an M27x1.25 puller (order no.: 99 99 799 00 – **not included**).

- **WARNING:** if you use a claw puller, the magnets in the rotor will come loose!

- Ensure that your Motobecane is securely positioned, preferably on a raised work platform, and that you have good access to the alternator side of the engine.

- Disconnect the battery and remove it from the motorbike. Please say goodbye to it at this point, as from now on you will have a 12-volt electrical system and – if you wish to fit a battery – you will need a 12-volt battery. Technically speaking, the system is capable of operating without a battery. However, unless your motorbike is classified as a classic, the Road Traffic Licensing Regulations (StVZO) require a parking light to be operational. You will need 12-volt bulbs for the headlights, speedometer lighting and rear light. The old horn can stay.

- Remove the old alternator, including all its components and cables

- The engine should now look as shown in the picture on the left.

- **Note:** The picture below shows a version of the engine that has a protruding edge above the alternator. Our system will, of course, fit this version as well.



- Detach the stator from the pre-assembled base plate. This is necessary to access the two mounting holes.

- **Important:** Make sure you note the position of the stator. Changing its position will inevitably result in a 120° shift in the ignition timing, rendering the mark invalid.

- **Note:** Take a look at the new base plate. You will find a red mark there (red circle in the picture). This is required for the ignition timing.

- Screw the base plate onto the engine block

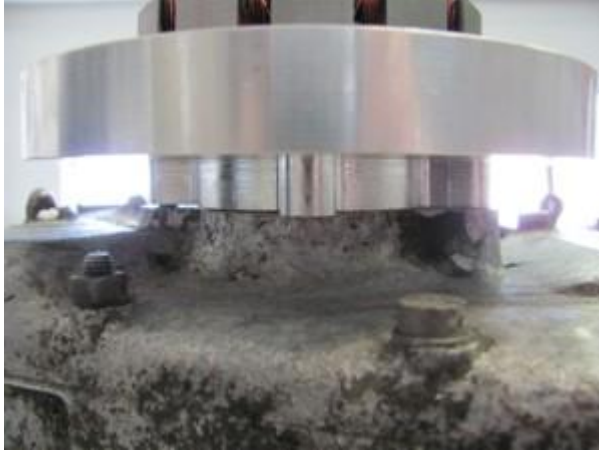

- Screw the base plate onto the engine block. Make sure that the base plate sits firmly on the block and does not tilt to one side, as shown in the picture on the left.

- Use the supplied M6x1.25 bolts and washers to secure it.

- You can now screw the stator back onto the base plate (3x M4).



- Remove the spark plug and move the piston to top dead centre. It does not matter which stroke the engine is in. As this is complicated with a kick-start, loosely place the new rotor onto the crankshaft stub so that you can use it to turn the crankshaft.

- Once the TDC position has been found, carefully remove the rotor again (taking care not to change the position of the crankshaft!) and position it so that the small line mark on the rotor aligns with the mark on the base plate.

- Carefully secure the rotor with the supplied M14 rotor nut.

- Take care not to move the crankshaft or twist the rotor at any time, otherwise the ignition timing will be incorrect. Screw the spark plug back into the cylinder.



- Secure the new ignition coil in a suitable location.

- This could be in a side panel, for example.

- Leave one of the two screws loose for now; this is where the earth cable will be connected.



- Mount the electronic rectifier/regulator and the electronic ignition timer (control unit) in a suitable location, e.g. in the side compartment.

- However, you can also position the parts anywhere else you wish.

- When installing the control unit, please note the small blue switch block on the upper narrow side of the black ignition timing unit. There are 4 small switches here that select different ignition timing curves.



- With this setting, maximum advance is reached at 3,000 rpm and remains there at all higher revs. Therefore, no over-rev protection is activated from 8,500 rpm onwards.

Connect the cables as shown in the relevant wiring diagram (Wiring Diagram 91ik_102)!

- To make it easier to feed the cable through narrow openings, or indeed to make this possible in the first place, the plug on the cable leading to the new control unit from the new alternator has not yet been connected to the terminal tabs at the end of the cable. You should only attach the plug once the cable has been fed through the engine opening. To do this ...

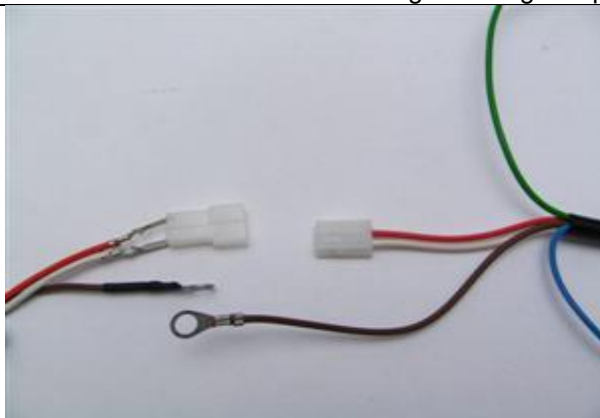

... take the female connector from the control unit with the red and white cables.

- Fit the loose 2-pin connector sleeve supplied with this part onto the plug, and insert the loose alternator cables (red and white) into the plug, aligning the contacts at the rear. Ensure that the contacts click into place within the plug housing. It is essential to ensure that these cables are positioned correctly within the plug:

- white goes to white
- red to red

- If you want (or need) to remove the cables from the connector housing, it is best to use a bent-open paperclip to push the barbs on the contact tabs to one side, so that the connectors can be released.

- The brown cables from the alternator and the control unit, fitted with ring terminals, are screwed onto the ignition coil's earth terminal (retaining clip). The system will not work without these connections! Please do not rely on the frame's earth. Paint, dirt and oil residues often prevent a good earth contact with the coil.

<p>- The blue and white cable from the control unit – the cut-off cable.</p> <p style="text-align: center;">- Note:</p> <p>If you experience ignition problems, disconnect this cable first (pull the plug). In most cases, you will then be able to continue your journey</p>	<p>- If it is connected to earth, the ignition will cut out!</p> <p>- We use this circuit configuration on vehicles that originally had magneto ignition (magneto rotor) and therefore also shut down due to a short circuit to earth.</p> <p>- These vehicles have a terminal on the ignition switch (on German vehicles: terminal 2) which is connected to earth when in the "OFF" position. The blue/white cable is connected to this terminal. This means that the ignition is switched off in the same way as before.</p> <p>Alternatively, an additional short-circuit (kill) switch can be used.</p>
<p>- The green or grey cable from the control unit ...</p>	<p>... is connected to the plug contact of the new ignition coil.</p>

WARNING! If possible, DO NOT extend the green cable from the control unit. This may cause ignition faults.
Under no circumstances should you route the ignition cable(s) and the control unit cable(s) together in a shared sheath or otherwise run them parallel to one another over a long distance. This leads to feedback and consequently to ignition faults, and in some cases may even destroy the control unit.

Connecting the alternator to the lighting circuit:

	<p>- The two black cables coming from the alternator supply power to the lights, horn, indicators, etc. They have nothing to do with the ignition.</p> <p>- This voltage must first be stabilised (regulated) and, for most applications, rectified, as it is initially alternating current.</p>
--	--

Warning: Any **reversal of positive and negative terminals** will result in **immediate destruction of the regulator, which is not covered by the warranty!** (You can clearly tell that it has been destroyed by the smell of burning!)

Regulator variant: with DC regulator with built-in smoothing capacitor (73 00 799 50), use circuit diagram **91ik_102**:

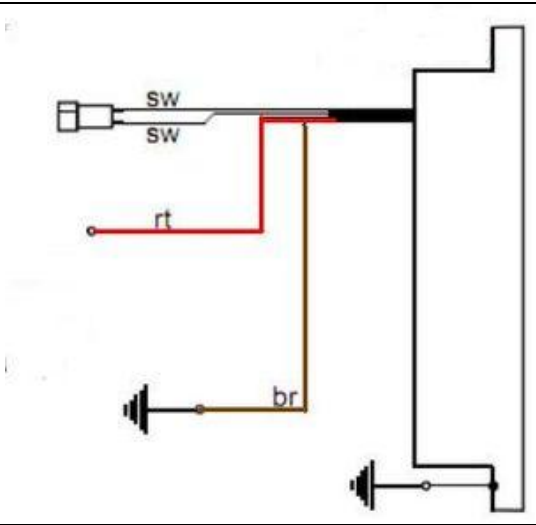

- the two black cables are connected to the black cables coming from the alternator
- the red cable is the 12V DC output
- the brown cable is the negative terminal and is connected internally to the regulator housing

- The high-voltage cable (ignition cable) ...

Please **do not use** 'Nology Super Cables' ('hot wire'). These cause interference in VAPE systems and can damage the electronics

... screw it into the ignition coil and fit the rubber cap over it. This is, of course, easier if you do this before fitting the coil to the vehicle. Please also use the ignition cable supplied and not an old, unidentified cable.

- You'll be doing yourself a favour if you fit new spark plugs and new spark plug leads (preferably with 1–2 kiloohms, but no more than 5) to your motorbike at this stage. More than enough interference can be traced back to 'seemingly good' cables, plugs and leads (including brand-new ones)!

- **Do not use** spark plugs with built-in interference suppression resistors **in conjunction** with interference-suppressed spark plug leads (this results in double the resistance). Always use only one interference suppression method.

- Finally – **before installing the battery and before starting the engine for the first time** – please take your time to check all fixings and wiring. Remember to replace all bulbs from 6 to 12 volts. Also bear in mind that you will now need a 12V battery. The horn can remain on 6 volts.

- If the system does not work straight away, please consult our troubleshooting page. As a first step, disconnect the blue cable between the relay and the ignition coil (disconnect the contact); most faults are hidden in the switch-off area.

- **IMPORTANT:** Please note that if **the crankshaft has been reconditioned** (previously), its alternator journal will have been over-machined and is therefore shorter. This causes the rotor to sit lower, which may result in contact between the rotor (the rivets being the lowest point) and the stator coil. The result is a damaged stator and, consequently, a loss of ignition.

Important safety and operating instructions – MUST be read in full and observed!

- Observe the safety instructions and requirements prescribed by the vehicle manufacturer and the automotive trade. Installation requires specialist knowledge.

The ignition marks applied to the material are for guidance only during installation. After installation, please check that the settings are correct using appropriate methods (such as a stroboscope) to prevent damage to the engine or risks to your health. You are solely responsible for the installation and correct adjustment.

- Caution Ignition systems generate high voltage – risk of fatal injury! Our ignition coils can reach up to 40,000 volts! If handled carelessly, this can not only cause severe pain but, more importantly, be harmful to the heart! People with pacemakers should not carry out any work on ignition systems. Always maintain a safe distance from the electrode and exposed high-voltage cables, and when testing, press the spark plug connector firmly to earth using an insulating object to safely discharge the voltage.

Never disconnect a spark plug lead to synchronise the carburettor! Never disconnect or touch the ignition cables whilst the engine is running or at starting speed. Only wash the vehicle when the engine is switched off.

- If your VAPE ignition cable was supplied with rubber spark plug connectors (*which do not have a built-in suppression resistor*), please use spark plugs with a built-in resistor (*to comply with local laws regarding electromagnetic compatibility requirements*). Alternatively, replace the cable(s) with standard ones and use shielded spark plug connectors (*under no circumstances, however, should you use suppressed spark plugs AND suppressed spark plug connectors at the same time. This would lead to interference, particularly difficulty in starting the engine*). The total resistance of the spark plug and spark plug connector combination should not exceed 5 kΩ.

- Remember that spark plug caps age and their resistance increases as a result. If an engine only starts when cold, the cause is almost certainly a faulty spark plug cap or a faulty spark plug. Do not use so-called spark-enhancing cables (e.g. Nology).

- After installation, please ensure you check that all retaining screws are tight. If the parts become loose, they will be damaged. We only tighten the screws loosely during pre-assembly!

- First, give the system you've just installed a chance to fire up before you start measuring and testing everything. Please also follow our instructions on how to check for a spark. All our parts are tested before dispatch. In any case, there is little you can measure on them. Under no circumstances should you attempt to measure the electronic components (including the ignition coil, except for its high-voltage output). You risk damaging them and will still not obtain any useful results!

Bear in mind that if the engine does not run straight away, this is often due to the carburettor, the intake rubber and, above all, the spark plug connectors and spark plugs (unfortunately even brand new ones); as a rule, the settings must also be adjusted after installing a Lima alternator. If the system does not run straight away, check the earth connections first and foremost, particularly between the chassis earth and the engine block.

Before you remove the parts again and send them to us for testing, please check our knowledge base to see if there is already an answer to your problem there. If not, please use our service ticket system to request specific assistance.

- If you have a system with a dual ignition coil, please note a few specific features of this coil. The ignition will only work correctly if both spark plugs are connected to the coil. This means you cannot simply remove one spark plug to test it, as each output is connected to the other's spark plug via the ground. If you really only want to test one side, the other coil output must be connected to ground.

- The spark produced by traditional breaker systems has a low energy level of around 10,000 volts and therefore appears yellow and thick. The spark produced by our systems is a high-energy spark of up to 40,000 volts and is therefore very sharply focused and blue, which makes it less visible. Furthermore, the spark is only generated at engine speeds reached when the kick-starter is engaged. Simply pressing the kick-start lever by hand does not produce a spark.

- Most of our systems combine the ignition and the alternator in one unit. You can tell this by the presence of a regulator. Apart from the voltage output by the regulator, there is little else you can measure on it. If you are not getting any power, check the earth connections and the wiring from the regulator to the ignition switch first and foremost. This important connection is often cut and overlooked during installation! Most PD systems have DC regulators/rectifiers. However, there are also AC regulators, which have specific features that need to be taken into account.

- Never carry out electrical welding on the vehicle without first completely disconnecting all electronic components containing semiconductors (regulator, ignition coil and control unit). The stator and rotor do not need to be removed. Only solder using equipment operated via series transformers, or unplug the soldering iron before soldering to prevent damage to the components caused by overvoltage. Never use copper paste on connectors or spark plugs.

- Electronic components are sensitive to reverse polarity. After carrying out any work on the system, always check that the battery is connected correctly and that the wiring is correct. Reverse polarity and short circuits will immediately destroy the control unit and the ignition coil! As a general rule, wires should always be connected colour to colour. Any exceptions are explicitly stated in the instructions. Damage caused by reverse polarity is not covered by the warranty.

- When assembling the rotor, please take care not to damage the magnets. Avoid applying direct mechanical force to the rotor. **Never place the stator inside the rotor when transporting the generator**; please follow our shipping instructions (packaging).

- Lightly oil the outside of the rotor; otherwise, it will rust quickly in the harsh environment (which is not harmful, but looks unsightly).

- Never use a claw puller or a hammer to remove the rotor. This may cause the magnets to come loose. Always use only a screw-in puller M27x1.25 (see installation instructions).

- If your vehicle is not going to be used for a prolonged period, you should disconnect the battery (if fitted) to prevent any slow discharge via the rectifier diodes. However, even with the battery disconnected, you will notice that it has discharged after a long period; this is normal.

- Please take note of these instructions, but don't let them unsettle you. Thousands of customers have already successfully installed our systems before you.

Good luck and enjoy your drive!

VAPE Schaltplan 91ik_102 (wiring diagram)

