

M783059900

**System 78 30 599 00**=> [€/€](#)**ignition for [Maico 250/400/440 \(1976-77\)](#)****note: to replace stock Bosch Magneto (not to replace Bosch dynamo or kroeber ignition!)****ignition only, no lighting support**

Magnet based ignition with own power supply from within the system. Replaces stock Bosch magneto and ignition coil.

You have to fasten the ignition coil outside of the engine.

**Advantage over old system:**

- all parts are new
- solid light output
- very stable ignition with high energy spark
- better starting and fuel burning

**Documentation:**

- [assembly instructions](#)
- [wiring diagram](#)
- [parts in the pack \(photo\)](#)

**If you can install and time a stock ignition and possess basic mechanical skills, you can install a VAPE system!**

**If you never have worked on your ignition, better have it done by someone who knows.**

VAPE can not monitor the compliance to those instructions, nor the conditions and methods of installation, operation, usage and maintenance of the system. Improper installation may result in damage to property and possibly even bodily injury. Therefore we assume no responsibility for loss, damage or cost which result from, or are in any way related to, incorrect installation, improper operation, or incorrect use and maintenance. We reserve the right to make changes to the product, technical data or assembly and operating instructions without prior notice.

**Please read these instructions fully and carefully before starting work on your motorcycle.** Please bear in mind that [any modification of the material as well as own repair attempts which have not been agreed with VAPE may result in a loss of warranty. Do not cut off wires. This leads to a loss of reverse polarity protection and often results in damage to electronics.](#) Also, please take note of the information provided on the information page for this system. Check that what you have bought really corresponds to the motorcycle you have. Wrong ignition settings may damage your engine and even hurt you during kickstart (violent kickbacks). Be careful during the first test runs. If needed change settings to safer values (less advance).



**IMPORTANT:**

**Designated use**

This system is designated to replace stock ignition systems in vintage and classic motorcycles whose engine characteristics have not been modified aftermarket. This system is not a tuning system and it will not bring significant increases in engine output. It does however significantly enhance roadworthiness and road safety by offering increased reliability compared with the aging stock systems . As our systems do not tamper with engine characteristics they do not increase emission of gassous pollutants and noise. In most cases emission of pollutants should be even reduced due to better combustion.

If used as designated the system therefore will not normally infringe the existing legal status of the motorcycle (this statement is valid for Germany, as this situation might be different in other countries, please consult your local road licencing regulations). This system is not suitable for use in competition events. If used other than designated warranty is voided and it might well be that you do not obtain the

	<p>desired results. In worst cases use not in accordance with designated use might entail legal roadunworthiness.</p>
	<p><b>During assembly imperatively start with assy of engine based parts</b> to see that those really fit before you start fitting the external parts. In many cases customers assemble those first and thereby often <a href="#">modify them in breach of warranty</a> which renders them unfit for renewed sale. <a href="#">Replacing old ignition systems is not a matter of taking something from a supermarket shelf as there have been very many types, versions and possibly unknown aftermarket modifications which harbour plenty of room for error.</a></p>
	<p>Our systems are <b>NOT</b> tested for use with other electronic devices (such as GPS, mobile phones, other 3rd party material.) and may cause damage to such parts. Possibly existing electronic tachometers will not work with the new system. Possibly existing safety switches and electronic valve controls are not supported. It might be that your motorcycle was originally equipped with an ignition that did limit top speed for legal reasons. The new system does not have such a facility, so check your legal situation beforehand</p>
	<p>If you have no expertise for the installation have it done by an expert or at a specialist's workshop. Improper installation may damage the new system and your motorcycle.</p>
	<p>If you have access to the Internet, best view those instructions online. You get larger and better pictures by clicking onto them and possibly updated information. System list at <a href="http://www.powerdynamo.biz">http://www.powerdynamo.biz</a></p>



**You should have received those parts:**

- rotor
- fastening screw / washer
- pre-assembled stator unit
- ignition coil / ht-cable
- screws, cable ties



To disengage your new rotor again, you will need a puller M27x1,25 (part-no.: 99 99 799 00 -**Not provided!**-).

**Note:** Never use a claw puller, a hammer or any other device, that will shake the magnets off.

---

**Notes on wiring:** Experience shows that in the course of time nearly every motorcycle undergoes changes to its wiring. As a result, wire colours and wires themselves on your bike might differ to those we describe. In case of doubt, please consult the original wiring diagrams.

---

Make sure your Maico rests securely on her stand, preferably on an elevated work bench and that you have good access to the magneto side of the engine.

---



Unscrew the generator cover and take it off. Unscrew the stock magneto, regulator and ignition coil and take it off.

Take the woodruff key from the crank. You will not need it any more. Please do not forget to do so, otherwise you will have trouble later on in the assembly. (Remark: This woodruff key does not actually hold your rotor on the shaft, this is done by the cone. It simply guides to the correct setting which will now be otherwise achieved.)

---

Lead the stator wire through the wire exit of the engine. Place the stock rubber grommer there to prevent dirt and water entry as well as wire damage on casing edge.



pic shows dynamo engine



Put the pre-assembled stator unit into the place of your old generator and screw it down with the 3 screws M6 supplied.

Take care that the cable leads through the enlarged opening without jamming.

pic shows dynamo engine and stator with lighting coils



Take a look at the stator's base plate. You will find here left from the first copper coil beneath the big black coil a small carved ignition marking. Encircled red here in picture. This is a timing mark.



Have a look at the new rotor. On its circumference you will find a small lasered on line.

---

Take the spark plug out. Place the rotor loosely onto the crank, check that it may move freely above the statorbase and use it for moving the piston. Turn the rotor and bring the piston into ignition position.



Take the rotor carefully off again without changing the crank's position and reset it onto the crank in such a way that the marking on the rotor aligns with the marking on the stator. In that position fasten the rotor carefully with the stock nut

Do not change the ignition position of the crank shaft during this procedure, otherwise you have to redo it.

---

The works at the engine are finished. Screw in the spark plugs again.

Fasten the ignition coil at a convenient place, favourably beneath the tank or inside a side case. Turn the HT-cable previously into the ignition coil. Leave one of the fastening screws loose, you have to connect a ground cable here.

Fasten the regulator/rectifier and the relay at a convenient place too, maybe beside the battery in the side case.

---

Connect the parts as shown in wiring diagram [51ik](#)

*	<p>To facilitate wire exit through the often small openings in the engine casing, the plastic plug of the generator's wiring that leads to the ignition coil have not been put onto the wire terminal. You should place the plug there only once all has been properly installed on the engine side.</p>	<p>Look for the ignition coil with its female plug and the two wires (red and white).</p> <p>Put the provided 2-position plug housing onto this plug and insert the two wires (red and white) from the generator. Make sure that the terminals engage securely in the housing and that you connect:</p> <ul style="list-style-type: none"> <li>• white to white</li> <li>• red to red</li> <li>• the brown wire with the eye terminal has to be screwed directly to the holderframe of the ignition coil. Please do not rely on the frame as conductor!</li> </ul>
<p>Should you need (or want) to get the terminals out of the plug housing again, enter a paper clip from front next to the terminals and push the little barb aside. Than pull the wire out.</p>		
*	<p>Remains the blue (sometimes blue/white) wire at the ignition coil. This is the kill (cut-off) wire.</p> <p><b>Note:</b> Should you experience ignition failures, disconnect as a first measure this blue wire. In many cases that will permit you to get mobile again (particulars see: <a href="#">technical help</a>)!</p>	<p><b>Connected to ground - it will stop ignition!</b></p> <p>This type of wiring is used in motorcycles which originally already had magneto ignition and therefore switched off by shortcircuiting against ground.</p> <p>Those vehicles have by design a main lock (or some kill switch) that connects a pin to ground when in OFF position (German bikes: pin 2). The blue(/white) wire of the ignition coil will be connected here. In that way the cut-off works like previously.</p>
*	<p>Screw the high tension (ignition) cable ...</p> <p>Please <b>do not use</b> any spark amplifying cables, such as "Nology supercables" or "hot wire". This will disturb the system and possibly damage it.</p>	<p>... into the ignition coil and pull over the rubber seal before mounting the coil (it will be easier).</p> <p>Please do use the cable arriving with the pack and not any old cable.</p>
*	<p>Finally - <b>and before first kickstart</b> - please re-check carefully all connections and fitments against the wiring diagram.</p>	

	Should something not work, please consult our <a href="#">trouble-shooting guide</a> on our homepage. As a first step disconnect the blue wire from the coil and re-test.
*	<b>IMPORTANT:</b> During <b>crank shaft repair</b> the dynamo shaft is often machined and gets shorter. The result is a rotor sitting lower, possibly touching now with its rivets the stator coil. The result is a destroyed stator and ignition failure. For <a href="#">more detail and how to check see (online) here</a> .

<b>Important safety and operating information</b>	
	Safety first! Please observe the <a href="#">general health and safety regulations motor vehicle repair (MVR)</a> as well as the safety information and obligations indicated by the manufacturer of your motorcycle.
#	The timing marks on the material are for general guidance only during first installation. Please check after assembly by suitable means (stroboscope) that settings are correct to prevent damage to the engine or possibly even your health. You alone are responsible for the installation and the correctness of settings.
#	<u>Ignition systems generate high tension!</u> With our material right up to 40,000 Volts! This may, if handled carelessly, not only be painful, but outrightly <u>dangerous</u> . Please do keep a safe distance to the electrode of your spark plug and open high tension cables. Should you need to test spark firing, hold the spark plug socket securely with some well insulating material and push it firmly to solid ground of the engine block. Never pull sparkplug caps when engine is running. Wash your vehicle only with engine at standstill and ignition off.
#	Should you have received in the kit HT cables with a fixed rubber boot(which does not contain a resistor) you might have to use spark plugs with an inbuilt resistor (or replace the cap with one containing a resistor) to comply with your local laws.
#	After installation, please <u>check tightness of all screws, even those preinstalled</u> . If parts get loose during run, there will be inevitably damage to the material. We pre-assemble screws only loosely.
#	Give the newly installed system a chance to work, <a href="#">before you start to check and test values</a> , or what is worse apply changes to it. Our parts have been checked before delivery to you. You will not be able to check much anyway. <b>At any rate do refrain from measuring the electronic components (such as ignition coil, regulator and advance unit). You risk severe damage to the inner electronics there. You will not get any tangible results from the operation anyway.</b> Bear in mind that also your carburetor, your spark plugs and spark plug sockets (even if completely new) might be the reason for malfunction. The general experience with our systems is that the carburetor will have to be re-adjusted to lower settings. Should the system not start after assembly, first disconnect the blue (or blue/white) cut-off wire directly at the ignition coil (or in some cases advance unit) to eliminate any malfunction in the cut-off circuitry. Check ground connections carefully, make sure there is a good electrical connection between frame and engine block. In case of troubles, please consult our <a href="#">Knowledge Base</a> first before you send off the material to us for checking



#	<p>The spark of classic, points based ignition systems has with about 10,000 Volts comparatively little energy and looks therefore yellow and fat (which however makes it highly visible). The spark from our system is a high energy spark with up to 40,000 Volts and therefore is needle thin focused in form, and blue in colour, which makes it not so visible. Furthermore you get spark only at kick-start operated speeds and not by pushing the kick-lever down slowly with your hand (as you might get with battery based ignitions).</p>
#	<p>Systems using a <a href="#">twin outlet ignition coils</a> have a few peculiarities. Please observe that during tests on one side, the other has either to be connected to an fitted spark plug or securely earthed/grounded. Otherwise there will be no spark on either side. Also with such open exits long and dangerous sparks may fly all over the coil.</p>
#	<p>Never do electric arc welding on the bike without completely disconnecting all parts containing semiconductors (ignition coil, regulator, advance) stator and rotor need not be taken off. The same is true for soldering. Before touching electronics disconnect the soldering iron from mains! <a href="#">Never use copper putty on spark plugs.</a></p>
#	<p>Electronics are very sensitive to wrong polarity. After work on the system, do check correct polarity of the battery and the regulator. Wrong polarity creates short circuits and will destroy the regulator, the ignition coil and the advance unit. As a rule, wiring will always be colour to colour. Instances, where colour jumps between wires are expressly mentioned in our instructions.</p>
#	<p>When you handle the new rotor, take care not to damage its magnets. Refrain from direct blows to the circumference of the rotor. <b>When transporting never put the rotor over the stator.</b> <a href="#">Observe our information relative to transport of the material.</a></p>
#	<p>Do not use spark plug sockets with a resistance of more than 5kOhm. Better use 1 or 2kOhm ones. Bear in mind that spark plug sockets do age and thereby increase their internal resistance. Should an engine start up only when cold, a defective spark plug socket and/or spark plug is very probably the cause. In case of problems check high tension cables too. Never use carbon fibre HT-cables, never use so called "hot wires" which promise to increase spark.</p>
#	<p>It is a good idea to cover the rotor in a thin layer of oil to reduce the risk of corrosion.</p>
#	<p>Never use a claw puller or a hammer to disengage the rotor. Its magnets might become loose in the event. We offer a special puller for disengaging the new rotor again (see assembly instruction)!</p>
#	<p>Should the motorcycle not be in use for some longer period, please disconnect the battery (so existing) to prevent current bleeding through the diodes of the regulator. Though, even a disconnected battery will empty itself after a while.</p>
#	<p>Please do observe these remarks, but at the same time, don't be afraid of the installation process. Remember, that before you, thousands of other customers have successfully installed the system. <b><i>Enjoy driving your bike with its new electric heart!</i></b></p>



# Schaltplan 71-599 (wiring diagram)

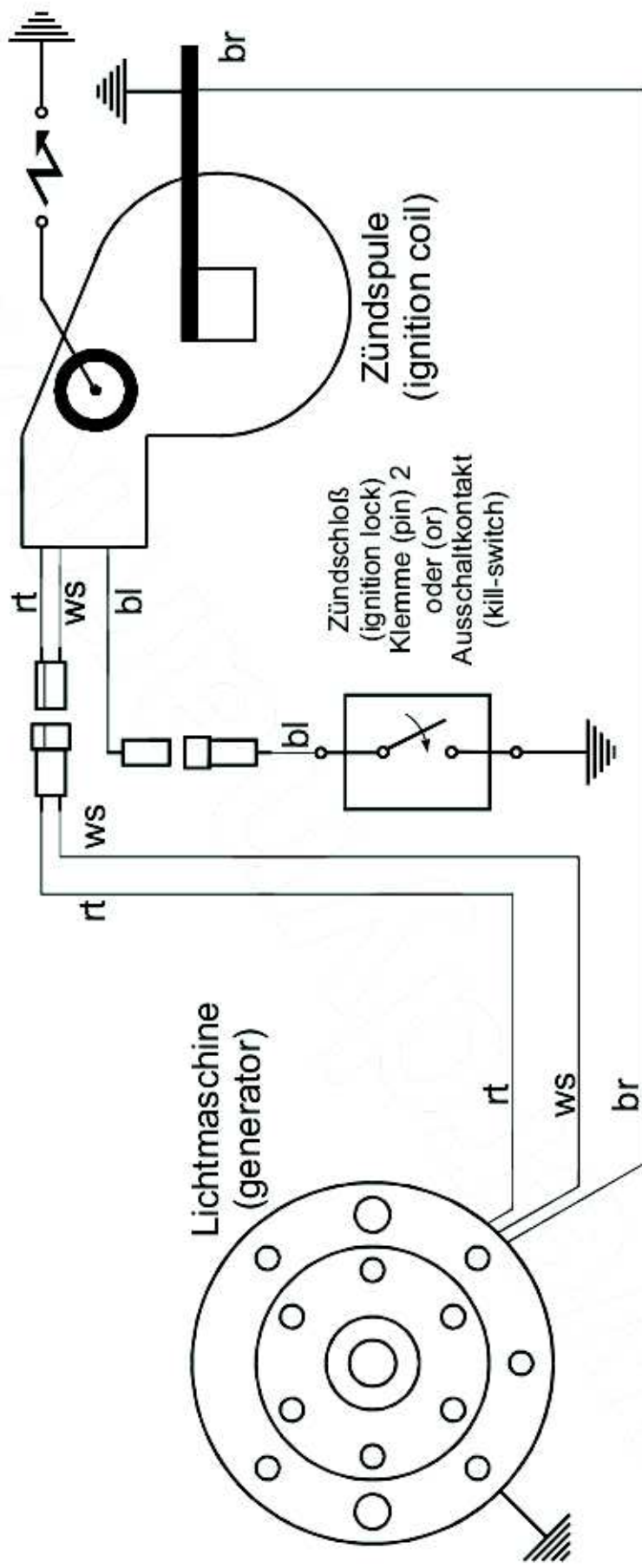

### Kabelfarben

(wiring colours):

bl = blau (blue)

br = braun (brown)

ge = gelb (yellow)

gn = grün (green)

gr = grau (grey)

rt = rot (red)

sw = schwarz (black)

ws = weiß (white)