

System 7081999017**for R50, R51/3, R51S, R60, R67, R67/2, R67/3, R69**

- with 17 mm crankpin (measured at wide end)

System 7081999020**for R50/2, R50S, R50US, R60/2, R60US, R69S, R69US**

- with 20 mm crankpin (measured at wide end).



Note, please see info on R68 camshafts

Note, not for BMW with lightened flywheel

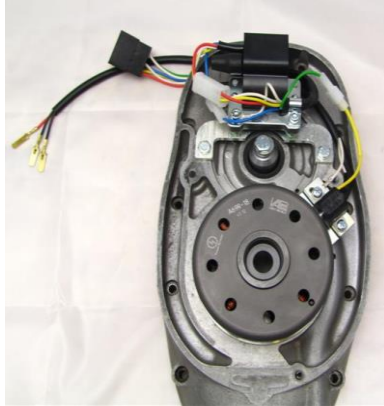

- Magneto with integrated solid state ignition, output at 12V/150W DC. Ignition with own power supply from within the system. Replaces old generator L45/60L, regulator, magnet unit, centrifugal advance unit in above listed BMW with either 17 or 20mm crankpin (measured at wide end).

- Does not require changes on crankcase. The system is technically capable of running without battery. All the 12v components are out of sight behind the front engine cover or tucked under the tank. No extra wires run to the headlight--the bike looks completely stock. The difference you will notice is how much easier the bike starts and runs, and a much improved lighting system..

- System 70 81 999 has ignition triggered on crankshaft which not only eliminates wear between crank and cam influencing ignition, but also frees the camshaft place to install de the ignition coil there (as this system does) Also timing is easier as you have at crank level full angles.

Advantage over original system:

- all parts are new
- solid state ignition and advance
- more light output
- very stable ignition with solid spark
- better starting, better fuel burning
- no wear anymore on collector, governor and points



M7081999017

Assembly instructions for system 7081999017 / 020 and 7081999R68	22.8.2022
<p>- If you can install and time a stock ignition and possess basic mechanical skills, you can install a VAPE! If you never have worked on your ignition, better have it done by someone who knows.</p>	
<p>- VAPE can not monitor the compliance to those instructions, nor the conditions and methods of installation, operation, usage and maintenance of the system. Improper installation may result in damage to property and possibly even bodily injury. Therefore we assume no responsibility for loss, damage or cost which result from, or are in any way related to, incorrect installation, improper operation, or incorrect use and maintenance. We reserve the right to make changes to the product, technical data or assembly and operating instructions without prior notice</p>	
<p><u>IMPORTANT</u></p>	
<p>- Please read these instructions fully and carefully before starting work on your motorcycle Please bear in mind that any modification of the material as well as own repair attempts which have not been agreed with VAPE may result in a loss of warranty. Do not cut off wires. This leads to a loss of reverse polarity protection and often results in damage to electronics. Also, please take note of the information provided on the information page for this system. Check that what you have bought really corresponds to the motorcycle you have. Wrong ignition settings may damage your engine and even hurt you during kickstart (violent kickbacks). Be careful during the first test runs. If needed change settings to safer values (less advance). During assembly check carefully that the rotor (flywheel) does not touch the stator coils or anything else, which may happen due to various circumstances and lead to severe damage.</p>	
<p>Designated use - This system is designated to replace stock dynamo/alternator & ignition systems in vintage and classic motorcycles whose engine characteristics have not been modified aftermarket. This system is not a tuning system and it will not bring significant increases in engine output. It does however significantly enhance roadworthiness and comfort by offering better lighting, better function of side indicators and horn and, compared with the aging stock systems, increased reliability. As our system does not tamper with engine characteristics it does not increase emission of gaseous pollutants and noise. In most cases emission of pollutants should even be reduced due to better combustion. If used as designated the system therefore will not normally infringe the existing legal status of the motorcycle. (Please check your local legal regulations!) This system is not suitable for use in competition events. If used other than the designated way, your warranty will be voided and it might well be that you do not obtain the desired results or, worst you loose legal roadworthiness.</p>	
<p> - VAPE guarantees homologated products marked with the “E” mark in the ring (E8 specifically for the Czech Republic), thereby ensuring a consistent conformity of the product properties with the relevant ECE homologation regulations (especially ECE R10.05). Inspection is regularly carried out by the competent authority.</p>	
<p>- The charging system is only suitable for use with rechargeable 12V (6V systems 6V) lead-acid batteries with liquide electrolyte or sealed lead-acid batteries, AGM, Gel. It is not suitable for use with nickel-cadmium, nickel-metal-hydride, lithium-ion or any other types of rechargeable or non rechargeable batteries.</p>	
<p>- This is a replacement system and not a copy of the stock material. The parts in this system therefore look different and might fit differently (notably ignition coil and regulator) requiring some adaptation by you.</p>	
<p>- During assembly imperatively start with assy of engine based parts to see that those really fit before you start fitting the external parts. In many cases customers assemble those first and thereby often modify them in breach of warranty which renders them unfit for renewed sale. Replacing old ignition systems is not a matter of taking something from a supermarket shelf as there have been very many types, versions and possibly unknown aftermarket modifications which harbour plenty of room for error.</p>	
<p>- Our systems are NOT tested for use with third party electronic devices (such as GPS, mobile phones, LED lighting etc) and may cause damage to such parts. Possibly existing electronic tachometers will not work with the new system. Possibly existing safety switches and electronic valve controls are not supported. It might be that your motorcycle was originally equipped with an ignition that did limit top speed for legal reasons. The new system does not have such a facility, so check your legal situation beforehand.</p>	

- If you have no expertise for the installation have it done by an expert or at a specialist's workshop. Improper installation may damage the new system and your motorcycle, possibly even lead to bodily harm.

- Before you order a system, please check whether a puller tool for the new rotor is included in the kit. If not, better order it at the same time. Never use anything other than the recommended puller tool to pull the new rotor again. Damage to the rotor as a result of use of other tools or methods is not covered by your warranty.

- The rotor is sensible to blows (including during transport). Before assembly, please always check for damage (on rotor without magnet plastification try to push the magnets aside with your fingers). After impact the glued in magnets might have broken loose, sticking to the rotor solely by magnetic force, so that one does not notice right away. During engine run the damage would be considerable. Before placing the rotor onto the engine, please make sure that its magnets have not collected any metal objects such as small screws, nuts and washers. That equally would lead to severe damage.

- **If you have access to the Internet, best view those instructions online.** You get larger and better pictures by clicking onto them and possibly updated information. System list at <http://www.powerdynamo.biz>

You should have received those parts:



1. wire harness
2. oil seal locking cam with holder screw in picture below this is the fastening set (screw M8 for new rotor, washer, screws M6 for stator plate)
3. rotor (flywheel)
4. battery cable, kill-wire
5. high tension cable (ignition cable)
6. regulator/rectifier
7. adapter plate with pre-mounted stator coil and pickup
8. advance unit 7072 on holder frame
9. CDI twin ignition coil on holder with cable

- Please note that the stator coil is only loosely fixed to the plate as you will have to lift it off a little for assembly. Further note that the sensor is only loosely fixed, as you will have to set it to correct gap.

- The supplied mounting plate for the new advance unit and the attached clamps may not fit on any BMW frame. It might need to be modified or replaced in individual cases.



- To disengage your new rotor again, you will need a puller M27x1,25 (part-no.: 99 99 799 00 **-Not provided!**).

- **Note:** Never use a claw puller, a hammer or any other device, that will shake the magnets off.



- To disengage your old rotor, you will need a puller screw M8x120 (part-no.: 70 80 899 90 - **Not provided!**). There are reports that this puller screw is too short for some material. The material we had here could be served with it.

- **Notes on wiring:** Experience shows that over time nearly every motorcycle experiences changes to its wiring. Additionally, most wires may have lost their original colours. For your reference we provide the original wiring diagrams of BMW 51/3 to 67 at our website.

- Make sure your BMW rests securely, preferably on an elevated work bench and that you have good access to the front of the engine. You will have to turn the front wheel from time to time for better access.

- Disconnect your battery and take it out of the motorcycle. Note that you will install a 12 volts system, so you will either need a 12 volt battery or you use the option of driving without a battery. You will still have to replace all light bulbs to 12 volt ones. The horn may stay at 6 volts.

- Drain your petrol tank into a safe canister. Make sure you do not spill petrol. Refrain from smoking. Disconnect the connecting tube under the petrol (gas) tank and take the tank off. Put it into a safe place for the duration of the works.

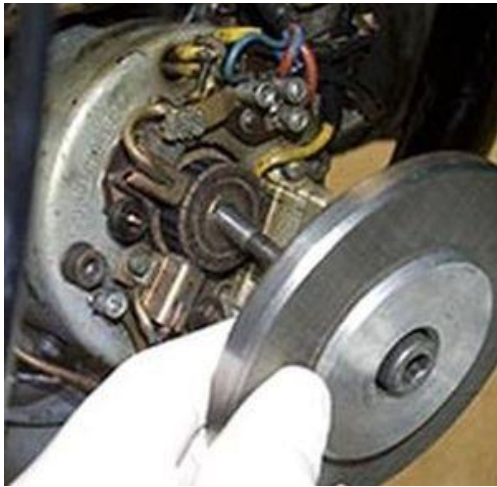

- Should your BMW (mostly R69US) have had a crank balancer (damper) than this can not be used any more.

- As the new flywheel has a larger diameter it has, to some extent, a balancing function.

- Unscrew the generator cover and take it off. Disconnect the wires from the old generator, regulator and magneto. At the generator there should typically be:

- one blue wire at generator terminal 61 (which runs to the charge light),
- one heavy red (might also be black) wire at generator terminal 30 (which runs to the battery plus)
- one heavy red (might also be black) wire at generator terminal 51 (which runs to the headlights main switch)
- one heavy brown wire (ground) which is attached to the ground terminal next to the negative (-) brush
- At the magneto unit you should have a red/black wire running to the ignition switches OFF position.



- Use a hex key 5 mm and remove the two screws retaining the field of the generator to the engine casing. Remove the field. You might need to gently bump its side with a rubber hammer to disengage it.

- Use a hex key 6mm and remove the screw that retains the advance unit and the magnetic rotor on the nose of the camshaft. To do that, you will have to hold the generators rotor with your hand using a piece of cloth to avoid injury. Take the centrifugal advance unit off.



- Now remove the 2 nuts (spanner 10) which hold the magnet unit and take the part off the engine casing. Use again the hex key 6mm and remove the screw that retains the rotor on the nose of the crankshaft. In place of the now removed holder screw install the BMW rotor puller and screw it in till the rotor pops off (again, you will have to hold the rotor with your hand, and you might well have to use a little force on the puller).



Rewire as follows:

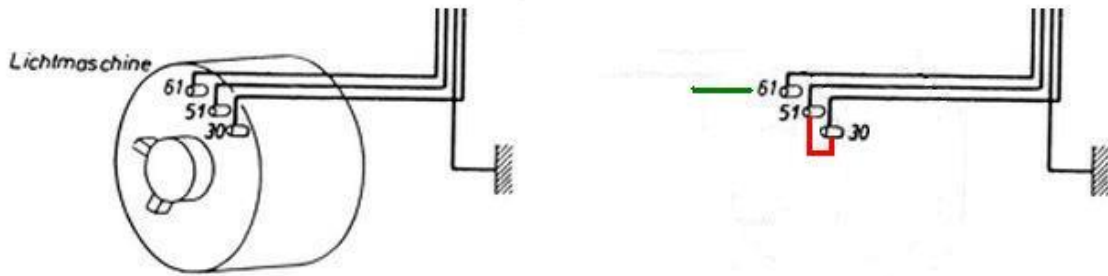

- the blue wire at generator terminal 61 (which runs to the charge light), gets connected to the red/green of the new regulator (unless you want to drive without battery, in that case do not connect, leave insulated idle)
- one heavy red (might also be black) wire at generator terminal 30 (which runs to the battery plus) is connected (bridge) to the heavy red running formerly to terminal 51 of the stock dynamo (see next item).
- one heavy red (might also be black) wire at generator terminal 51 (which runs to the headlights main switch) is connected (bridge) to the heavy red running formerly to terminal 30 (see item above)
- one heavy brown wire (ground) which is attached to the ground terminal next to the negative (-) brush secure to some other ground point.

- Integration between the original general electric system (lighting, horn etc) and the new system is at the battery (or should you drive without at the wires normally running to the battery).

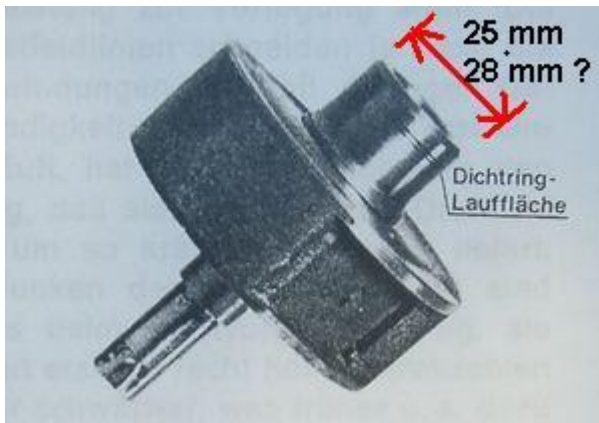

- Check the diameter of the sealing stud on the original magneto rotor. You normally have here 25 mm. On R68 and some R69 however that is 28 mm.



- Should you find 28 mm there, you will have to replace the existing oil seal 28 mm by one with 25 mm. Otherwise you will not seal the oil there.



- Place the provided oil-seal cam onto the camshaft and fasten it with the special screw M8x40. Please don't forget to use the provided washer.

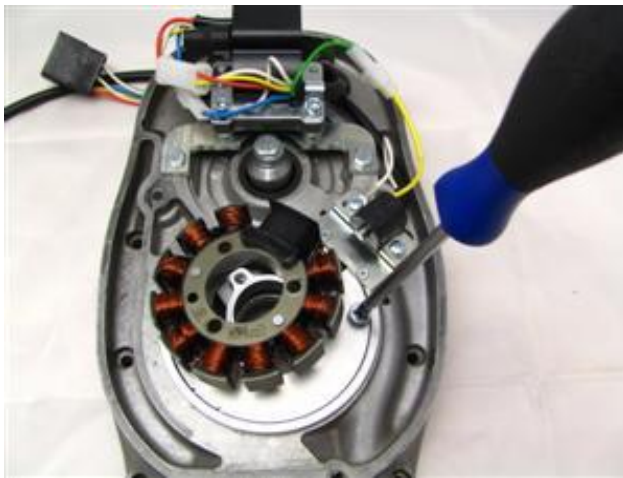

- The new stator unit is pre-assembled so that you can recognize its structure more easily. To install it, it has to be partially disassembled however. Take care not to damage the paint insulation of the coils. Unscrew the new stator coil from its base plate (the 3 hex screws) and lift it a little away from it so that you can access the mounting holes in the base plate.

- Now put the base plate consisting of

- the steel ring with holder plate for sensor (pick up) and pickup module
- and the base plate (aluminium)

- onto the engine block and screw it down with the 2 screws M6 provided.

- The pick up module will show into the direction of about 2 o'clock. The stator coil will still hang loosely from the assembly.



- Now put the stator coil back into its position on the plate, taking care not to damage the wires. Make sure that the inner opening of the stator unit slots evenly over the elevated fixing rim of the base plate - otherwise the coil will sit loop sided and will touch the rotor, damaging it.

- Screw the coil down with the 3 hex screws M6x30 and tighten. The thick black coil will now face upwardly, the cable should be in the little recess of the engines casing (top of generator).

- The single white wire will be connected to ground at the left sensor holder screw.

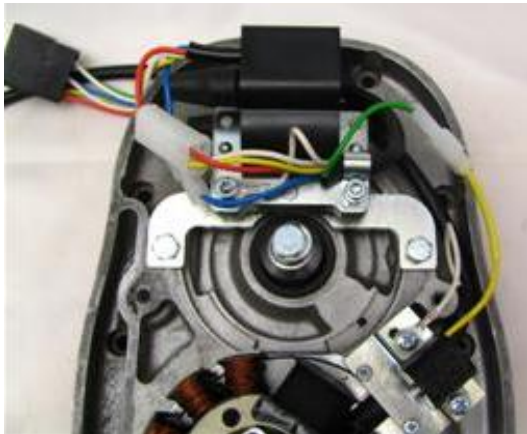

- Screw the 2 high tension cables (if supplied as one, cut it into 2) into the ignition coil.
- Fix the pre-assembled coil unit with the provided 2 screws M5 at height of the camshaft - there where the magneto unit had been before.
- Connect the plug with the female terminal on the yellow wire from the sensor with the fitting plug with the male terminal at the green wire which you find at the ignition coil unit.



- The short harness pieces running from the new generator and the coil unit will be ushered with their plug-ends through the top opening into the rear top engine compartment. They wait there to get connected to the rest of the assembly.
- The new harness piece sports a rubber grommet that fits the original wire exit on top of the engine.

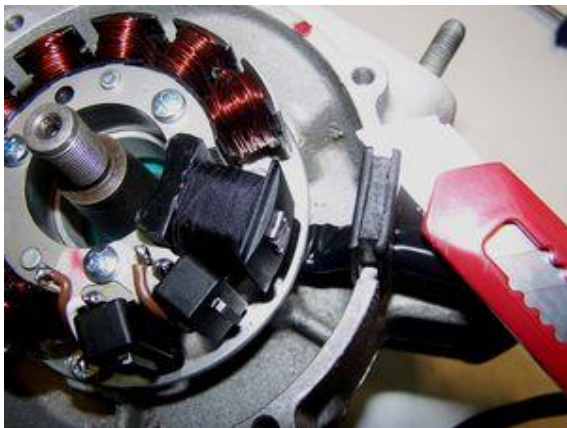

- There is a rubber grommet on the stator wire. Press it into the wire exit opening and then cut the surplus material off carefully.

(Photo shows different motor!)

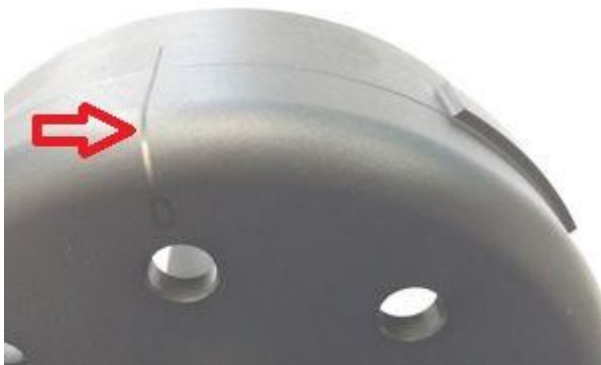

- Have a look at the new rotor. You will find on the circumference some long protrusion and a lasered on line which goes right up to the top where it is marked with a "0".
- The elevated sign is there to trigger ignition. However it does not do so when this elevation reaches the sensor, but after it has gone past it as the system needs to calculate the advance based on engine speed (the time the protrusion needs for one passage used as reference).

Ignition will be timed with crankshaft in TDC.



- Take the spark plugs out. Place the rotor provisionally onto the crank shaft (without screwing it down there) for using it as a turning knob. Bring the crank shaft into TDC (in German OT) by using the spyhole.

- Pull off the rotor again (you will possibly need the a M27x1.25 puller for this) without changing the crank shaft position.

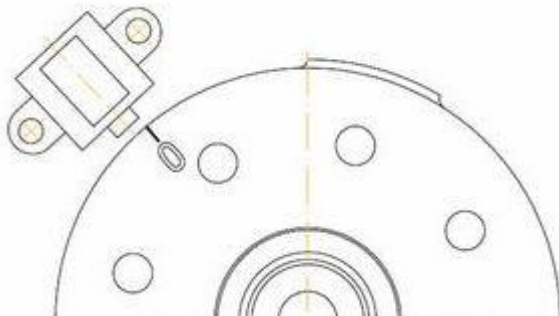

- Than place the **rotor back onto the shaft in such a way, that the 0-marking line aligns with the rh edge of the sensor pin as shown in the sketch here.**

- Now fasten the rotor with the supplied screw (and washer). Make sure not to change the crank's position during this.

- Minor deviations of 1-2mm are harmless (the original centrifugal governor had the some tolerances).



- Should you have a rotor that does not yet have the 0-line than you can place this marking easily by yourself as follows:

- Cut some strip of paper with **37mm** length, place this on the left side of the trigger sign and mark its end an the circumference with some marker pen. You than have the needed marking.

- Fasten the rotor with the provides screw M8x35 and the washer. To disangage the rotor again, use a puller M27x1,25 (never a claw puller or hammer blows!).

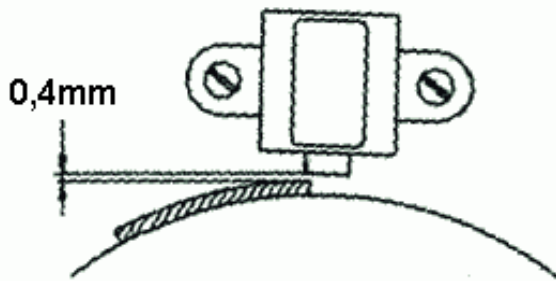

- Turn the new rotor by hand and check the gap between the pick up and the elevated nose (protrusion) on the circumference of the rotor. This has be be set to 0.5 mm. You may set the gap by loosening the 2 holder screws a little and shifting the unit accordingly. After setting the gap, make sure to fasten to 2 screws properly. Even if by chance the gap was correct, fasten the screws! They are loose at time of delivery.

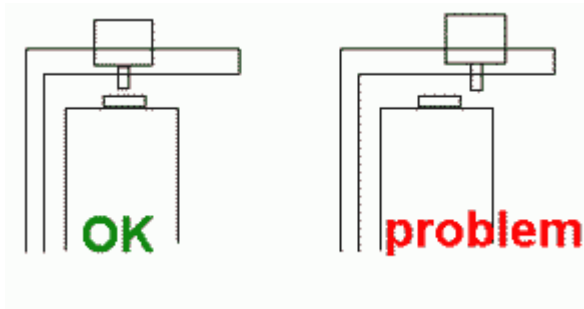

- With the rotor set, check that the protrusion runs in level with the the sensor and not outside its track
- This problem actually only happens if there is a different crankshaft in or a wrong rotor fixed. Still, worth checking, as you will not get spark with a situation like that.
- Equally check that the rotor turns freely above the base and the stator.

- Now, the advance unit and the new regulator/rectifier have to find a place on the motorcycle. The regulator is well dimensioned and does not need to get direct airflow. The following is a (pre-configured) proposal. Sure that you may install the units in any other convenient place.



- The new electronic advance unit is pre-mounted on a holder plate which itself will be fitted with 3 clamps to the frame under the petrol (gas) tank.
- The supplied mounting plate for the new advance unit and the attached clamps do not fit on any BMW frame. It must be modified or replaced in individual cases.
- Have a look at the advance unit (the black box). You will notice on the side the wires come out 4 small switches. They are used to activate different advance curves inside the bow.
- There are 2 curves which will work with your BMW. They are activated as follows.



- For those BMW engines the following curve is used:
- all switches are to OFF (opposite of ON) giving at start 8° and at 3000 revs/min and higher 38° BTDC.



- The new regulator/rectifier could be fitted under the rear holder for the petrol tank. (On this proposal the customer has used a self made unit plate.) For this, unscrew the nut (spanner 13) securing your BMW's tank holder and put your new regulator plate (with the regulator on it) underneath. The regulators cooling fins will face upwards. Put the nut back, do not forget to put the washer back.
- You may fit the regulator/rectifier in any other way.



- As this picture shows, it is also possible to mount the regulator on the advance plate. This will depend on specific frame configuration.

- This is how the parts are connected between them (on a table)

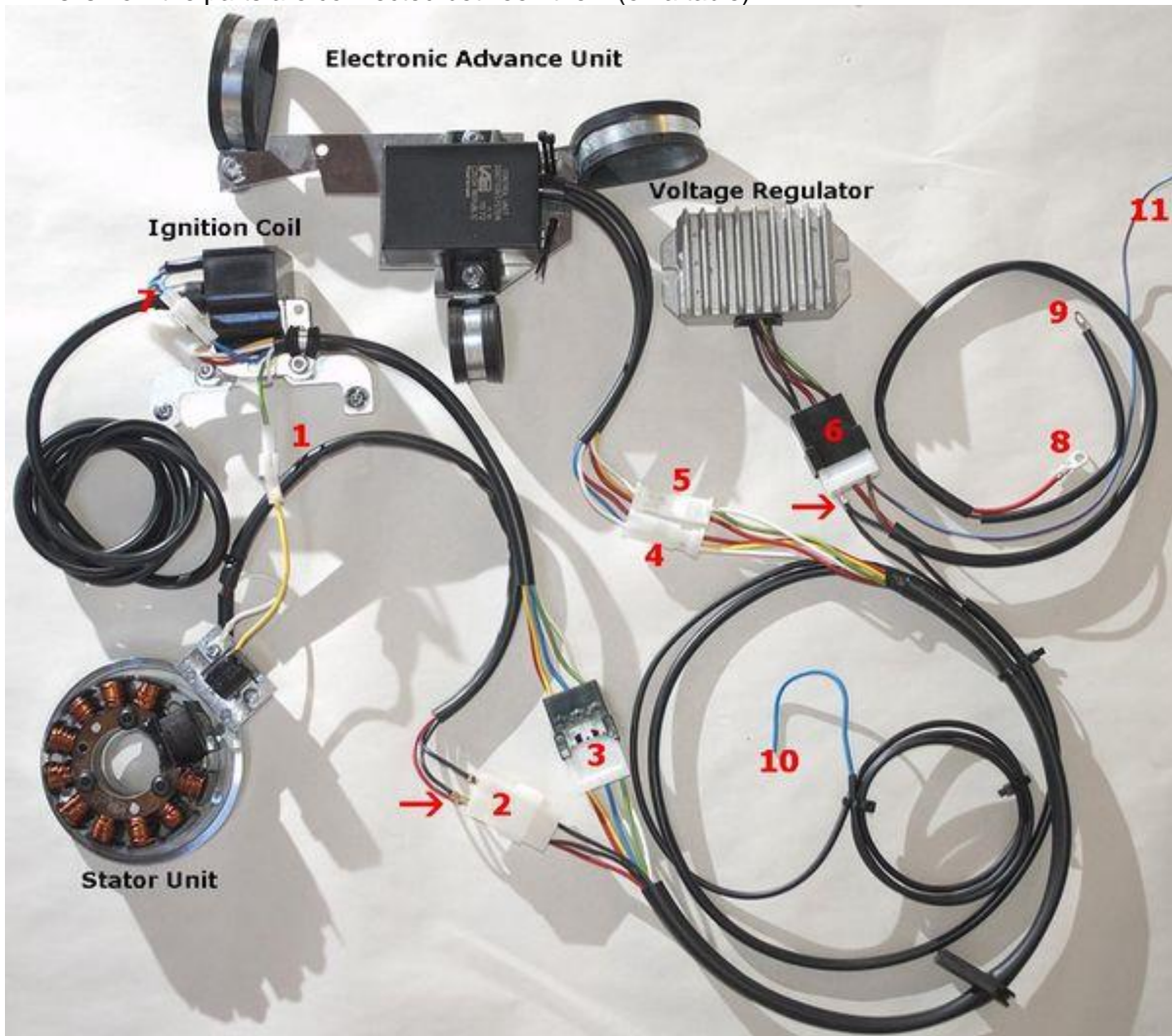

1. is a 1pin plug connecting yellow from sensor to green in the loom
2. is a 4pin plug connecting red and 2x black from stator to red and 2x black in the long loom (no matter which black to which black)
3. is a 6pin plug connecting the wires from the ignition coil to the long loom. Green to green, red to red, yellow to yellow, blue to blue and the 2 whites to 2 whites (no matter how)
4. is the connection between the male plug of the advance unit (recognisable as there is a blue/white in) and the matching plug at the long loom. here are white to white, red to red and blue/white to yellow.
5. is the connection between the female plug of the advance unit to its matching counterpart. Here are red to red, white to white and yellow to green.
6. is the 6pin plug to the regulator. here are red to red, brown to brown and 2x black to black (No matter how). Also green/red to blue/red.
7. is fitted at the ignition coil. Blue to blue, yellow to yellow, red to red and white to white.
8. is batterie plus (red)
9. is batterie minus (brown)
10. is the blue cut off wire which connects to pin 2 of the main switch
11. is the wire to the charge control indicator bulb (blue/red)

- As per the above, the new additional harness connects as follows:

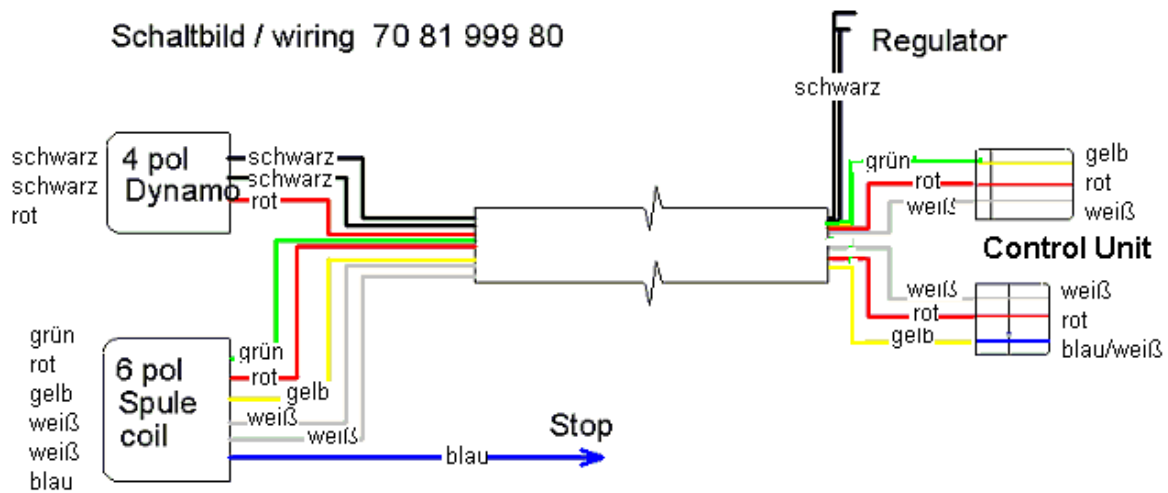

- The 4 pole plug on the wires running from the dynamo with the wires 2 x black and 1 x red

- The 6 pole plug on the wires green, red, yellow, blue and 2 x white running from the new ignition coil unit

- The new piece of harness divides after exiting from the engine. Its end terminals outside the engine will be connected as follows:

- The 4 pole female plug with wires red, white and yellow (only 3 wires)

- The 4 pole male plug with wires red, white and green

- The single blue wire

- Should you need (or want) to get the terminals out of the plug housing again, enter a paper clip from front next to the terminals and push the little barb aside. Then pull the wire out.

- **Important!** Never run the high tension cable and the cable of the advance unit closely in parallel (say in one shielding). This will trigger back coupling that disturbs ignition and might even damage the advance unit.

... has to be connected with its fitting counterpart at the new harness piece sporting wires in the same colours. Please note that this piece of loom **DOES NOT REPLACE** the original wiring at your motorcycle, but is supplementary.

... has to be connected to its matching counterpart with wires of same colour on the new piece of harness.

... gets connected with the fitting opposite plug at the advance unit. Here you get a colour change from yellow to blue/white (on the advance unit).

... gets connected with its opposite member at the advance unit. Here you have again a change of colours from green to yellow.

... is the kill wire. It has to be led towards the ignition lock and connects there to pin 2 (as had been the old magneto). If this wire connects to ground, ignition is off.

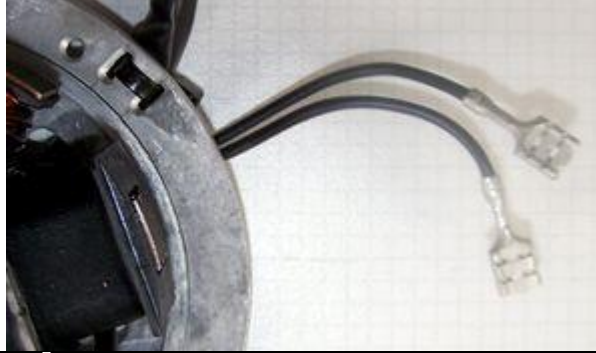
Connecting VAPE alternator to lighting circuit (via regulator):

- The 2 black wires running from the stator coil carry the voltage for lights, horn, flashers etc. They have nothing to do with ignition.
- This voltage (something between 10 and 50 volts AC) has however to be stabilized (regulated) and for most uses rectified into direct current (DC) as it primarily is alternating current (AC).



Attention: Any **confusion between plus and minus** (with the DC versions) leads to **immediate destruction of the regulator**. This will not constitute a warranty case as it is negligence! One can recognize a burnt regulator mostly by its sharp smell.

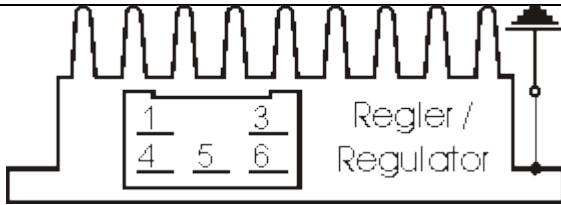

- The new regulator/rectifier has a compact plug with 6 positions, of which *one* is not used. A female plug cover fitting to this plug is delivered. Into this female plug you have to insert the following wires (which have terminals that snap into the plug):

The two black cables leading from the generator ...

... connect to pins 1/4 of the new regulator (from there correspondingly black wires lead inside the unit). It does not matter which wire connects to which of the both terminals (1/4) as they carry alternating current.

The new brown cable with the round eye terminal ...

... connects pin 3 of the regulator unit (from there correspondingly a brown wire goes inside the unit) with the negative terminal on the battery or (in case you drive without battery) to ground/earth (chassis).

The new red cable with the round eye terminal ...

... connects to pin 5 of the new regulator (from there correspondingly a red wire goes inside the unit). Here your regulated positive voltage comes out to connect to positive terminal of the battery, or (in case you drive without battery) to the positive pin of the main switch (ignition lock, German bikes: pin 51/30).

Make sure that you have a **16A-fuse** between battery and vehicle circuitry.

The green/red wire at pin 6 of the new regulator ...

... is for the charging light. You connect there the wire that formerly did run from the control light to the original regulator.

Sure that this control only functions with a battery present. Should you drive without battery but still connect the wire, you will see that the light glows even as the generator generates voltage. So without battery, do not connect it.

Screw the high tension (ignition) cables

... into the ignition coil and pull over the rubber seals before mounting the coil (it will be easier). Please do use the cable arriving with the pack and not any old cable.

- You will do yourself a favour to treat your bike to new spark plugs and spark plug sockets (preferably some between 0-2kOhm). Plenty of problems are to be traced back to "apparently good" (even completely "brand-new") spark plugs, terminals and cables.
- Do not use spark plugs with an intern suppression resistor. NGK (e.g.) offered such spark plugs coded with an "R" (for resistor).



- In our twin outlet coils both ends of the secondary go to the spark plugs.
 - Typical resistance between both exits is 6.2kOhm. Both exists fire at the same time (as many twin systems do). Sparks will be polarised however at a 180 degrees difference which might manifest when you strobe it.

- Ignition will only work correctly if both plug terminals are connected. You may not test one side with the other open (not sitting on the mounted spark plug). This is because (effectively) each exit uses ground from the other. That means also that both plugs are working in serial, adding resistances, so better use low resistance spark plug (resistor) sockets and make sure they are good. If in doubt, measure resistance on a **hot** socket (warm it up before measuring).

- Is the flow from ground of one side via spark plug there, via coil, to the other spark plug and its ground interrupted you get no spark - on neither side. If you really want to test only one side, put the HT wire of the other to ground (earth it) than it will work. Sometimes a coil deprived of its ground from the other side searches for a substitute - with some solid fireworks around it to the chassis.

- Finally - **and before installing the battery and before the first kickstart** - please re-check carefully all connections and fitments against the wiring diagram. Do check battery and light bulbs for correct voltage (12V).

- Should something not work, please consult our trouble-shooting guide on our homepage. As a first step disconnect the blue wire from the coil and re-test.

- IMPORTANT: During **crank shaft repair** the dynamo shaft is often machined and gets shorter. The result is a rotor sitting lower, possibly touching now with its rivets the stator coil. The result is a destroyed stator and ignition failure.

Important safety and operating information

- Safety first! Please observe the general health and safety regulations motor vehicle repair (MVR) as well as the safety information and obligations indicated by the manufacturer of your motorcycle. The timing marks on the material are for general guidance only during first installation. Please check after assembly by suitable means (stroboscope) that settings are correct to prevent damage to the engine or possibly even your health. You alone are responsible for the installation and the correctness of settings.

- Ignition systems generate high tension! With our material right up to 40,000 Volts! This may, if handled carelessly, not only be painful, but outrightly dangerous. Please do keep a safe distance to the electrode of your spark plug and open high tension cables. Should you need to test spark firing, hold the spark plug socket securely with some well insulating material and push it firmly to solid ground of the engine block.

Never pull sparkplug caps when engine is running. Wash your vehicle only with engine at standstill and ignition off.

- You should have received the HT Cable with the fixed rubber cap (*which does not contain a resistor*) as a part of the kit, you should have to use a spark plug with an inbuilt resistor (*or replace the cap with the one containing a resistor*) to comply with your local laws (*Electromagnetic compatibility requirements*).

- Do not use a spark plug cap(s) containing a resistor **WITH** a spark plug(s) containing a resistor at the same time. It would cause problems, especially difficult engine starting. The total resistance of cap and spark plug combined should not exceed 5kOhm.

- Remember that candle plugs age, increasing resistance. If an engine only starts when it is cold, it is very likely that a defective spark plug connector or faulty spark plug is the cause. Do not use so-called ignition-reinforcing cables (e.g. Nology).

- After installation, please check tightness of all screws, even those preinstalled. If parts get loose during run, there will be inevitably damage to the material. We pre-assemble screws only loosely.

- Give the newly installed system a chance to work, before you start to check and test values, or what is worse apply changes to it.

Our parts have been checked before delivery to you. You will not be able to check much anyway.

At any rate do refrain from measuring the electronic components (such as ignition coil, regulator and advance unit). You risk severe damage to the inner electronics there. You will not get any tangible results from the operation anyway. Bear in mind that also your carburetor, your spark plugs and spark plug sockets (even if completely new) might be the reason for malfunction. The general experience with our systems is that the carburetor will have to be re-adjusted to lower settings. Should the system not start after assembly, first disconnect the blue (or blue/white) cut-off wire directly at the ignition coil (or in some cases advance unit) to eliminate any malfunction in the cut-off circuitry. Check ground connections carefully, make sure there is a good electrical connection between frame and engine block.

In case of troubles, please consult our Knowledge Base first before you send off the material to us for checking.

- The spark of classic, points based ignition systems has with about 10,000 Volts comparatively little energy and looks therefore yellow and fat (which however makes it highly visible). The spark from our system is a high energy spark with up to 40,000 Volts and therefore is needle thin focused in form, and blue in colour, which makes it not so visible. Furthermore you get spark only at kick-start operated speeds and not by pushing the kick-lever down slowly with your hand (as you might get with battery based ignitions).

- Systems using a twin outlet ignition coils have a few peculiarities. Please observe that during tests on one side, the other has either to be connected to an fitted spark plug or securely earthed/grounded. Otherwise there will be no spark on either side. Also with such open exits long and dangerous sparks may fly all over the coil.

- Never do electric arc welding on the bike without completely disconnecting all parts containing semiconductors (ignition coil, regulator, advance) stator and rotor need not be taken off. The same is true for soldering. Before touching electronics disconnect the soldering iron from mains! Never use copper putty on spark plugs.

- Electronics are very sensitive to wrong polarity. After work on the system, do check correct polarity of the battery and the regulator. Wrong polarity creates short circuits and will destroy the regulator, the ignition coil and the advance unit. As a rule, wiring will always be colour to colour. Instances, where colour jumps between wires are expressly mentioned in our instructions.

- When you handle the new rotor, take care not to damage its magnets. Refrain from direct blows to the circumference of the rotor. **When transporting never put the rotor over the stator.** Observe our information relative to transport of the material.

- Do not use spark plug sockets with a resistance of more than 5kOhm. Better use 1 or 2kOhm ones. Bear in mind that spark plug sockets do age and thereby increase their internal resistance. Should an engine start up only when cold, a defective spark plug socket and/or spark plug is very probably the cause. In case of problems check high tension cables too. Never use carbon fibre HT-cables, never use so called "hot wires" which promise to increase spark.

- It is a good idea to cover the rotor in a thin layer of oil to reduce the risk of corrosion.

- Never use a claw puller or a hammer to disengage the rotor. Its magnets might become loose in the event. We offer a special puller for disengaging the new rotor again (see assembly instruction)!

- Should the motorcycle not be in use for some longer period, please disconnect the battery (so existing) to prevent current bleeding through the diodes of the regulator. Though, even a disconnected battery will empty itself after a while.

- Please do observe these remarks, but at the same time, don't be afraid of the installation process. Remember, that before you, thousands of other customers have successfully installed the system.

Enjoy driving your bike with its new electric heart!

